

REVISIONS				
SYM	ZONE	ECN, ERN NO.	DATE	APPRD.
C		PROPOSAL	Apr 07, 2008	A.G.
D		PROPOSAL	Jun 26, 2008	A.G.

THIS IS A CAD DRAWING. DO NOT MANUALLY REVISE.

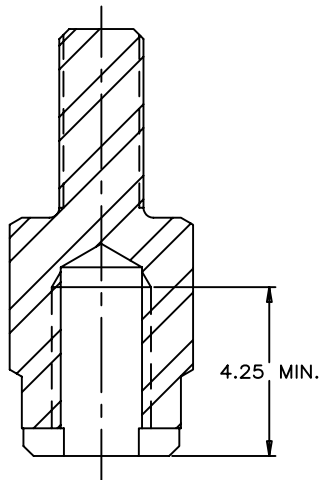

SECTION A-A

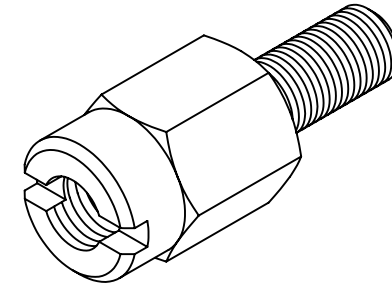

ISOMETRIC VIEW

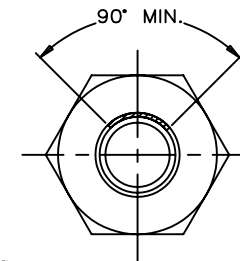
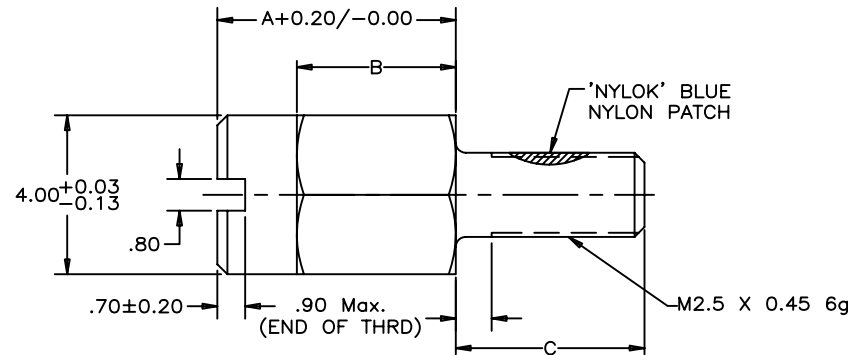

PART NUMBER	DESCRIPTION	A	B	C
U65-404-40P	REGULAR SCREW	6.00	4.00	4.75
U65-404-41P	SELF-LOCKING SCREW (WITH 'NYLOK' BLUE NYLON PATCH)	6.00	4.00	4.75
U65-404-42P	LONG THREAD SCREW	5.40	3.40	5.35

NOTES:

1. MATERIAL: STEEL AISI 12L14.
2. PLATING: 2.54 μ m MIN. NICKEL PLATING.
3. PART TO BE FREE FROM BURRS.
4. PART TO BE BULK PACKED.
5. GAGE FOR SCREW INSPECTION TO MEET REQUIREMENTS OF ASME B1.3M SPECIFICATION.

DRAWN	L.DENG	DATE	2004/09/22	Amphenol Canada Corp. TITLE JACK SCREW INFINITY RECEPTACLE SCREW LOCK TYPE	
DESIGNED	L.DENG	DATE	2004/09/22		
CHECKED	J.SI	DATE	2004/09/22		
I. E. APPRD.					
Q. A. APPRD.				DWG. DRAWING NO. A P-U65-404-4XP	
DWG. APPRD.					
ENG. REL. NO.				REF. EAR# 12538 DIMENSIONS ARE IN INCHES [mm]	
CODE ID. NO.			03554		
SCALE		2/1	WT.	SURF.	SHEET 1 OF 1

THIS DOCUMENT CONTAINS PROPRIETARY INFORMATION AND SUCH INFORMATION MAY NOT BE DISCLOSED TO OTHERS FOR ANY PURPOSE OR USED FOR MANUFACTURING PURPOSES WITHOUT WRITTEN PERMISSION FROM AMPHENOL CANADA CORP.